

**PERAET 2021****International Scientific Conference «PERISHABLE AND ETERNAL: Mythologies and Social Technologies of Digital Civilization-2021»****ALGORITHMIC BASIS OF BATTLE NEURAL NETWORKS AND  
CRISIS PHENOMENA IN MODERN SOCIETY**

Ibragim E. Suleimenov (a), Oleg A. Gabrielyan (b)\*, Sergey A. Malenko (c), Yelizaveta S. Vitulyova (d), Andrey G. Nekita (e)

\*Corresponding author

(a) V. I. Vernadsky Crimean Federal University, Simferopol, Russian Federation, esenych@yandex.kz

(b) V. I. Vernadsky Crimean Federal University, Simferopol; Yaroslav-the-Wise Novgorod State University (NovSU), Veliky Novgorod, Russian Federation, gabroleg@mail.ru

(c) Yaroslav-the-Wise Novgorod State University (NovSU), Veliky Novgorod, Russian Federation, olenia@mail.ru

(d) Almaty university of power engineering and telecommunications named after Gumarbek Daukeev, Almaty, Kazakhstan, lizavita@list.ru

(e) Yaroslav-the-Wise Novgorod State University (NovSU), Velikiy Novgorod, Russian Federation, beresten@mail.ru

**Abstract**

Based on a comparison of the perspective algorithmic foundations of combat neural networks control and processes occurring in administrative systems, a consistent interpretation of the “control” category and the concept of “distributed control” is proposed. It is shown that the interpretation of these categories should take into account the existence of a hierarchy of information processing systems, the lowest level in which is occupied by the number systems, and the highest (of the known) – human intelligence. It is shown that control, understood as a philosophical category, is not reduced to command generation (information transfer). This category also reflects the formation of information products of a higher order (languages, communication rules, etc.). It is shown that such an understanding of the “control” category makes it possible to create the basis for the purposeful creation of distributed control systems (including administrative ones), alternative to the existing ones, which are built on hierarchical pyramids. The hierarchical principle of managing complex systems, including administrative ones, no longer satisfies modern society needs for fundamental reasons associated with the objective laws of information theory. The increasing complexity of systems, including those designed to ensure the stable functioning of state apparatus, leads to the hierarchical principle of management becoming inapplicable due to a significant increase in information distortions during its compression and decompression at intermediate levels of the hierarchical pyramid. An alternative is the principle of distributed control, the means for practicing which are, among other things, combat neural networks, which are also of independent applied interest.

2357-1330 © 2021 Published by European Publisher.

*Keywords:* Artificial intelligence, bureaucracy, loss of control, neural networks, post-industrial war

## 1. Introduction

The term “post-industrial war” was updated by the events in Nagorno-Karabakh (Artsakh) in 2020, which clearly demonstrated the capabilities of robotic weapons, which, however, have been discussed for a very long time (Boccardo et al., 2021; Garcia-Bernardo et al., 2016; Jaber, 2019; Torossian et al., 2020). Such trends will intensify, especially since there is a demand for the use of artificial intelligence (AI) for military purposes (Briscoe & Fairbanks, 2020; Zhang & Lu, 2021).

At a minimum, we are talking about the use of systems that ensure the functioning of unmanned combat vehicles in autonomous mode. More broadly – about forecasting enemy actions, managing groups of unmanned combat vehicles, about the fastest possible rapid response to changes in the situation in the theater of operations, etc.

The emerging trends are expected to result in the creation of combat neural networks (CNNs) (Mun et al., 2020) or their analogues. According to the terminology (Mun et al., 2020), the CNN is a collection of unmanned combat vehicles that form integrity by exchanging signals between its elements and processing incoming information (including commands from the control center) in approximately the same mode as the human brain. Information processing, including the formation of local commands, is carried out by the network as a whole, there are no dedicated control elements in it, which, among other things, significantly reduces its vulnerability.

The algorithms for the functioning of the CNN are also of interest from the point of view of practical philosophy – a relatively new scientific direction, which, among other things, is looking for general theoretical (for example, methodological) foundations of specific scientific research.

Any war, including a hybrid one, is a concentrated embodiment of the capabilities possessed by the opposing sides. Post-industrial war is a mirror reflecting the processes taking place in modern society, which, due to the rapid development of telecommunication networks, becomes a man-machine system. In post-industrial war in any of its forms, it is man-machine systems that also enter into confrontation, which is also true in relation to information wars.

The key category in this regard is the management category. The problems of managing systems of various natures have been discussed for a long time in the literature (Volkova et al., 2021), however, the emergence of man-machine systems transfers them to another level that requires a completely different – philosophical – understanding. Such attempts, in particular those related to the study of the role of AI in modern society, are known (Van der Maas et al., 2021), but they only touched on certain aspects of the problem under consideration.

## 2. Problem Statement

The essence of the "control" category in conditions when the emerging man-machine systems have already caused certain qualitative transformations of civilization should be disclosed at the philosophical level.

In the foreseeable future, modern society may well face a crisis of loss of manageability, when decisions made by the leadership will cease to be carried out or will be carried out in a form distorted

beyond recognition. The corresponding trends are already clearly visible. Top leaders of states are increasingly forced to solve problems that, in theory, should be solved by lower-level administrators.

The nature of the crisis of loss of controllability is mainly determined by the peculiarities of the formation of information flows in modern society, which uses the hierarchical principle of managing any large institutions (See Figure 1).

Any system organized according to a hierarchical principle assumes the presence of a closed control loop. Information from the lowest level, at which real activity takes place, goes to the next level of management. There it is processed, transformed into a more compact form, and enters the subsequent levels of the administrative hierarchy, up to the level of the top management of the system, where, in theory, the main decisions are made.

Management decisions, regardless of their form, are de facto an information product. This information moves through the hierarchy levels in the opposite direction, which closes the control loop.

If the system is simple enough, and the number of levels in it is relatively small, then such a system may well function quite efficiently. However, with the increasing complexity of administrative systems, the hierarchical principle of management could not help but begin to lose efficiency.

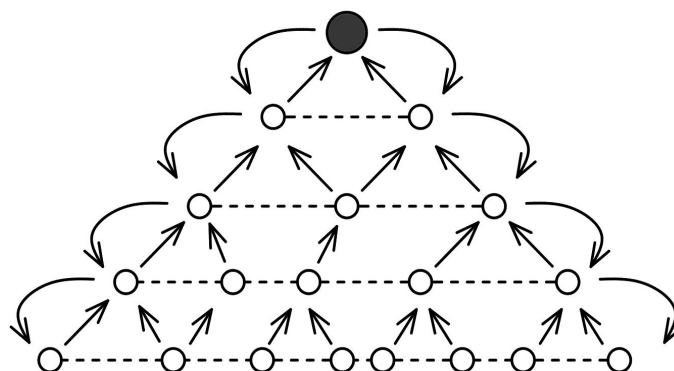

**Figure 1.** Scheme of information flows in the administrative system, built on the basis of the hierarchical management principle

This is a reflection of the fundamental laws of information theory. In particular, the information compression/decompression procedure carried out at each of the hierarchical levels is associated with inevitable distortions of information. The administrator at any level of the system has a certain freedom in choosing the interpretation of factual material, the interpretation of incoming orders, etc.

Information compression is one of the most important functions performed by administrators. Otherwise, higher-level managers would be drowned in a stream of information unprepared to make decisions. Similarly, decompression of control information (developing specific orders for subordinates based on orders from management, for example) is also mandatory – top management cannot give orders to each of the grassroots executors directly.

There are other factors leading to a crisis of loss of control. In particular, these include the processes of informational self-organization that occur at intermediate levels of the administrative hierarchy (Suleimenov et al., 2017).

Consequently, the complication of the organization of society will sooner or later raise the question of alternatives to the hierarchical principle of management, the creation of management schemes in which the top management of a corporation or state will be relieved of the need to maintain a cumbersome bureaucratic apparatus that is becoming increasingly ineffective and in many respects even uncontrollable.

### **3. Research Questions**

1) proof of the need for a comprehensive interpretation of the "management" category, taking into account the fact that management can be indirect;

2) proof of the expediency of the transition from the hierarchical principle of management of complex systems to the network;

3) disclosure of the essence of the "management" category on the basis of a dialectical approach to the interpretation of the category of information and the existence of a hierarchy of information processing systems.

### **4. Purpose of the Study**

The aim of this study is a philosophical interpretation of the "control" category and the concept of "distributed control", as well as proof that in modern conditions it is necessary to ensure the transition from the hierarchical principle of management of complex, including social systems to distributed.

### **5. Research Methods**

The main method used in this work is to consider the problems of managing the CNN, as well as the problems of managing modern administrative systems from a uniform perspective. This approach allows us to reveal the concept of "distributed management" from a general philosophical point of view and further give an interpretation of the very "management" category on this basis.

Comparison of these objects allows one not only to reveal the essence of the category of "management", but also to lay the foundations for the modernization of approaches to the management of complex systems on an innovative basis.

The basis for choosing the objects to be compared is, in particular, the results of works (Urrea et al., 2020), in which the voting procedure in the Academic (or other) Council was considered. It was shown that there are conditions under which the voting organ is converted into a neural network, more precisely, into an analogue of the Hopfield neuroprocessor. Under such conditions, the decision on a particular issue is made not by the members of the Council, but by the neural network formed by them – the decision-making moves to the transpersonal level of information processing.

Similarly, any informal horizontal communication between administrators, even at a particular level of the hierarchy shown in Figure 1, leads to the appearance of analogs of neural networks. One of the most studied properties of such networks is the ability to recognize patterns, which in relation to the problem of managing complex systems means the ability to filter information.

Filtering information is one of the most essential tools for information impact. So, if middle managers move to coordinated actions, then they will be able to provide management only with the information that will induce the leader to take the actions they need. The essence of the processes of informational self-organization in administrative systems is, however, that the controlling informational influences can also be formed spontaneously – due to the fact that middle-level administrators de facto form a neural network. As in the case with the voting Council discussed above, the decision is taken de facto at the transpersonal level of information processing. It is these factors that determine the essence of such a phenomenon as bureaucracy.

## **6. Findings**

The interpretation of the essence of the category of control, as shown in this work, is closely related to the problem of creating the algorithmic basis of the CNN. We emphasize that the issue of using artificial neural networks to control robotic weapons is actively discussed in the current literature (Urrea et al., 2020; Zheng et al., 2021).

This question allows us to reveal the essence of the concept of "distributed control", which allows excluding intermediate levels from the diagram in Figure 1, i.e. make it work in a mode similar to the brain.

A person has intelligence due to the fact that the neurons of his brain exchange signals with each other. Among them, however, control elements cannot be distinguished. Control is “transferred” to the system as a whole (Figure 2).

Let us note that the issue of distributed control of complex systems, in fact, has a long history. The “invisible hand of the market” is an example of the implementation of self-organization processes. Laws and other regulations are precisely macroscopic, i.e. network control. They do not regulate the specific actions of market actors, but set certain restrictions. (Of course, a refined market economy has never existed, but this does not change the essence of the matter).

The "free market" is just one example of network (macroscopic) regulation of a complex system. Its fundamental difference from all the others is only in the fact that it arose naturally. There are many such regulators to offer.

The question of the algorithmic basis for the functioning of the CNN (as an analogue of a wasp swarm, the integrity of which is generated only by the information exchange of the system), therefore, goes beyond a highly specialized framework. The solution of this problem allows one to raise the question of the essence of macroregulators of complex systems as such.

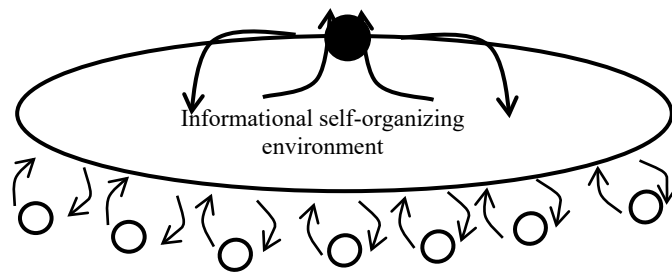

**Figure 2.** The scheme of managing a complex system through transpersonal structures

Figure 3 shows a diagram of the BNS functioning in the network control mode. It emphasizes that commands are sent from the control center to all elements of the network at once (See Figure 3).

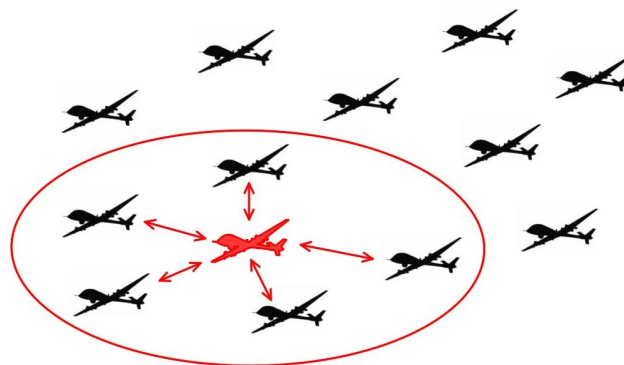

**Figure 3.** CNN (combat neural networks) distributed control scheme

Classical neural networks function differently: various signals are fed to the inputs of various neurons of the input layer (See Figure 4a, Figure 4b), forming, for example, a certain digitized image.

Executable commands for a specific CNN element are formed by this element itself on the basis of processing data received from the immediate environment, from sensors that register the operational situation, as well as commands received from the control center.

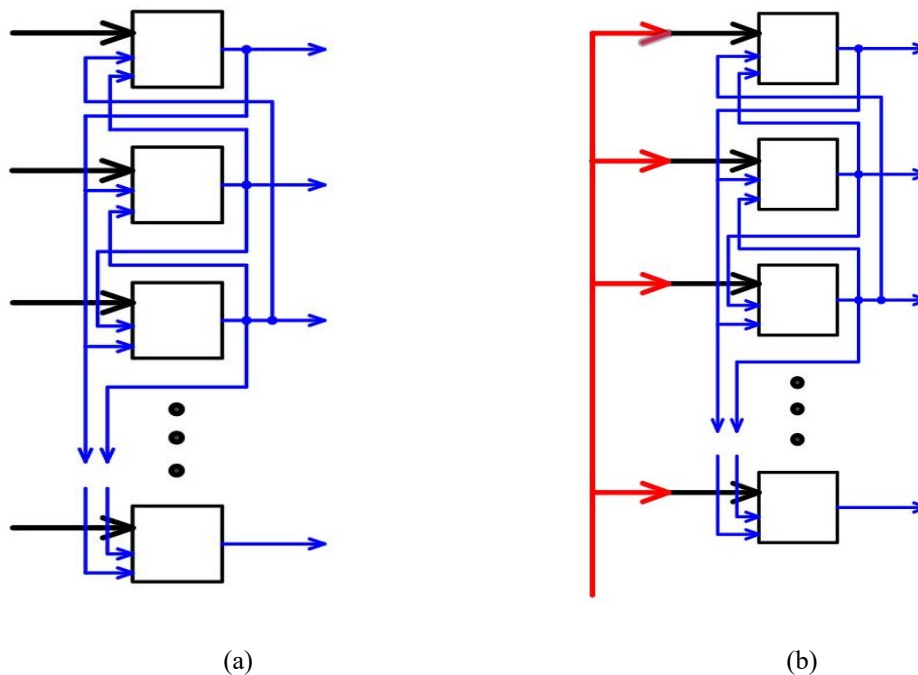

**Figure 4.** Scheme of information processing of a classical neural network (a) and information processing by a network with macroscopic control (b)

In this respect, CNNs function like the “open market” and other macroscopic control systems. This approach not only greatly simplifies the control of the neural network (from the point of view of operator actions), but also makes it possible for the CNNs to operate in an autonomous mode. The operator, metaphorically speaking, acts rather as a “legislator” for the neural network, rather than as the one who makes specific decisions “on the ground”.

The comparison of the two systems of a very different nature shows that when analyzing the category of "control", it is not just the concept of "information" that becomes extremely important, but the concept of "information object". It reflects the fact that information processing systems themselves form a well-defined hierarchy, and such systems themselves have a purely informational basis (Vitulyova et al., 2020). So, the rules for operating with binary or decimal numbers can be considered as "information" in the usual sense of the term. However, these rules are a higher-order information object – with their help, one can get new information (for example, the result of adding two numbers). To an even greater extent, this property is inherent in information objects belonging to higher levels of the hierarchy (Vitulyova et al., 2020). So, using Maxwell's equations, it is possible to construct calculations for radar systems, etc. It is an information object that allows one to receive other information objects.

Further, any complex system generates a well-defined information object – its communication shell, which is in dialectical unity with the "material component". This interpretation corresponds to the consideration of matter and information as paired dialectical categories (Suleimenov et al., 2018; Suleimenov et al., 2020)

A manifestation of the dialectical unity of a complex system and its communication shell is the fact that quite often the processes occurring in the communication shell begin to exert a pronounced

influence not on the behavior of the system as a whole, an example of which is the phenomenon of bureaucracy (Vitulyova et al., 2020).

Consequently, the most effective should be recognized such management schemes that "launch" the mechanisms of self-organization, directing them in the right direction. The most effective management is networked or distributed. This corresponds to the "synthesis" of control information objects of a higher level than the one to which the direct commands to be executed belong.

## 7. Conclusion

Comparison of two objects of different nature – combat neural networks and administrative control systems – clearly shows that they have the main feature of a complex system. They form a new quality that allows for interpretation in the language of the hierarchy of information objects (information processing systems). The system acquires a communication shell in which the processes of informational self-organization can take place, leading to the emergence of new information objects (an example is the phenomenon of bureaucracy).

Informational self-organization can be both spontaneous and directed, which is the basis of macroscopic (distributed) management. An example of a system with macroscopic control can be considered a state with a market economy, the impact on which is carried out through legislative mechanisms.

From the point of view of the dialectical theory of information, "legislation" that forms the communication shell of a complex system consisting of economic agents is information of a higher level of hierarchy than direct directives.

Consequently, what is called management is also hierarchical in nature: management tools differ from each other in which of the hierarchical levels the management information belongs to. The higher this level, the less concrete efforts are needed to implement the management procedure itself.

Consequently, there is every reason to follow the path of artificial synthesis of control information objects of higher orders both in relation to administrative systems and in relation to technical ones (combat neural networks – CNN, for example). In the future, this will make it possible to abandon the hierarchical principle of management, which, as applied to administrative systems, already obviously does not meet the current needs of modern society.

## References

- Boccardo, P., Striccoli, D., & Grieco, L. A. (2021). An extensive survey on the Internet of Drones. *Ad Hoc Networks*, 102600. <https://doi.org/10.1016/j.adhoc.2021.102600>
- Briscoe, E., & Fairbanks, J. (2020). Artificial Scientific Intelligence and its Impact on National Security and Foreign Policy. *Orbis*, 64(4), 544-554. <https://doi.org/10.1016/j.orbis.2020.08.004>
- Garcia-Bernardo, J., Dodds, P. S., & Johnson, N. F. (2016). Quantitative patterns in drone wars. *Physica A: Statistical Mechanics and Its Applications*, 443, 380-384. <https://doi.org/10.1016/j.physa.2015.09.055>
- Jaber, J. (2019). Drones Proliferation: Should We Worry. *Technical Report*, 72. <https://apps.dtic.mil/sti/pdfs/AD1106740.pdf>
- Mun, G. A., Vitulyova, E. S., Kabdushev, Sh. B., Kadyrzhan, K. N., & Suleimenov, I. E. (2020). Problematika postindustrialnoj vojny i delovye obrazovatelnye ekosistemy. *Vestnik Nacionalnoj*



- inzhenernoj akademii Respubliki Kazahstan* [Post-industrial war issues and business educational ecosystems. *Bulletin of the National Engineering Academy of the Republic of Kazakhstan*], 4(78), 88–93.
- Suleimenov, I. E., Nurtazin, A. A., Gabrielyan, O. A., Shaltykova, D. B., Tasbulatova, Z. S., & Panchenko, S. V. (2017). Byurokratiya s tochki zreniya teorii samoorganizatsii. *Obrazovatelnye resursy i tekhnologii* [Bureaucracy from the point of view of the theory of self-organization. *Educational resources and technology*], 36-44. <https://doi.org/https://cyberleninka.ru/article/n/byurokratiya-s-tochki-zreniya-teorii-samoorganizatsii>
- Suleimenov, I., Massalimova, A., Bakirov, A., & Gabrielyan, O. (2018). Neural Networks and the Philosophy of Dialectical Positivism. *MATEC Web of Conferences*, 214, 02002. <https://doi.org/10.1051/mateconf/201821402002>
- Suleimenov, I. E., Vitulyova, Y. S., Bakirov, A. S., & Gabrielyan, O. A. (2020). Artificial Intelligence. *Proceedings of the 2020 6th International Conference on Computer and Technology Applications*. <https://doi.org/10.1145/3397125.3397141>
- Torossian, B., Bekkers, F., Sweijjs, T., Roelen, M., Hristov, A., & Atalla, S. (2020). The Military Applicability of Robotic and Autonomous Systems. *The Hague Centre for Strategic Studies*, 1-30. [https://doi.org/https://mk0hcssnlsb22xc4fhr7.kinstacdn.com/wp-content/uploads/2021/01/RAS\\_Military\\_Applicability\\_Final\\_.pdf](https://doi.org/https://mk0hcssnlsb22xc4fhr7.kinstacdn.com/wp-content/uploads/2021/01/RAS_Military_Applicability_Final_.pdf)
- Urrea, C., Kern, J., & López, R. (2020). Fault-tolerant communication system based on convolutional code for the control of manipulator robots. *Control Engineering Practice*, 101, 104508. <https://doi.org/10.1016/j.conengprac.2020.104508>
- Van der Maas, H. L. J., Snoek, L., & Stevenson, C. E. (2021). How much intelligence is there in artificial intelligence? A 2020 update. *Intelligence*, 87, 101548. <https://doi.org/10.1016/j.intell.2021.101548>
- Vitulyova, Y. S., Bakirov, A. S., Baipakbayeva, S. T., & Suleimenov, I. E. (2020). Interpretation of the category of “complex” in terms of dialectical positivism. *IOP Conference Series: Materials Science and Engineering*, 946, 012004. <https://doi.org/10.1088/1757-899x/946/1/012004>
- Volkova, V. N., Fleishman, B. S., Tarasenko, F. P., & Loginova, A. V. (2021). Further Development of Potential Feasibility Theory for Complicated Systems According to the Unified General-System Principle. *Knowledge in the Information Society*, 446-453. [https://doi.org/10.1007/978-3-030-65857-1\\_37](https://doi.org/10.1007/978-3-030-65857-1_37)
- Zhang, C., & Lu, Y. (2021). Study on artificial intelligence: The state of the art and future prospects. *Journal of Industrial Information Integration*, 23, 100224. <https://doi.org/10.1016/j.jii.2021.100224>
- Zheng, K., Zhang, Q., Hu, Y., & Wu, B. (2021). Design of fuzzy system-fuzzy neural network-backstepping control for complex robot system. *Information Sciences*, 546, 1230-1255. <https://doi.org/10.1016/j.ins.2020.08.110>