

**SCTMG 2021**  
**International Scientific Conference «Social and Cultural Transformations in the Context of**  
**Modern Globalism»**

**ALTERNATIVE PENSION CAPITAL: OPPORTUNITIES OF THE**  
**RUSSIAN FINANCIAL MARKET**

Rustam Alievich Yalmaev (a)\*, Lyubov Vladimirovna Grigoryeva (b),  
Oxana Yurevna Vatyukova (c)  
\*Corresponding author

(a) Chechen State University, 32A, Sheripova Str., Grozny, 364024, Russia, r.yalmaev@chesu.ru,  
(b) Volgograd State University, 100, University Ave., Volgograd, 400062, Russia, grigorievalv@volsu.ru,  
(c) Volgograd State University, 100, University Ave., Volgograd, 400062, Russia, vatukova\_o\_u@volsu.ru

**Abstract**

Due to the failure of the Russian pension reform, the population of the country faces the urgent need of finding other sources for the formation of individual pension capital. To do this, financial and non-financial instruments may be used that are not part of the state pension protection system. Thus, this concerns the formation of alternative pension capital. The paper describes the economic mechanism of the above capital, the principles of its formation. The key principle of allocating the financial capital of an individual as an alternative pension is targeting. It was this that formed the basis of further empirical research and made it possible to select the optimal financial instruments available to the population in the Russian financial market. The concentration of attention on individual investment accounts (IIA) and bank deposits showed the high prospects of the former. This is caused by an increase in the level of accessibility of this instrument (development of financial infrastructure), higher level of profitability, and the availability of tax incentives. Deposits in this case lose, since the level of real profitability is falling, and since 2021, income from deposits over 1 million rubles will be taxed on the income tax, but this does not indicate the complete futility of this instrument. Another area is the creation of pension deposits in commercial banks. They also take into account the long-term nature of investments and are more attractive to people with a conservative pension strategy and low disposable income.

2357-1330 © 2021 Published by European Publisher.

*Keywords:* Alternative pension capital, pension protection, financial market, pension



## **1. Introduction**

The persistent transformation of the pension protection system of the population in Russia still does not allow stabilizing financial flows to the state pension fund and ensuring a decent standard of living for pensioners. As of 2020, the poverty level of pensioners in Russia is 13.2 % (the share of the population with incomes below the all-Russian living wage). It is common knowledge that the planning horizon in the formation of pension rights is quite long-term, therefore, constant changes in the economic mechanisms for the formation of pensions create the risks of loss (or non-receipt) of pension payments in the future.

The state of uncertainty that arises from the external state influence on pension rules within the state pension protection system requires the population to find alternative opportunities for the formation of passive income at the end of work. This concerns the alternative pension capital.

## **2. Problem Statement**

The high standard of living of pensioners is one of the priorities of a socially oriented state. The created and constantly reformed economic mechanisms of the system of pension protection of the population in Russia, throughout the entire period of reforms (almost 20 years) could not achieve the desired result. In these macroeconomic conditions, the orientation towards a paternalistic approach in the formation of an individual pension strategy is impractical, so it is necessary to explore alternative options for the formation of the pension capital.

## **3. Research Questions**

The study of the possibilities of forming alternative pension capital, including through the Russian financial market, allows: expanding the understanding of the essence of the economic mechanisms of the system of pension protection of the population; enhancing the range of tools used in the formation of individual (family) pension protection; reducing risks from political decisions in the pension sector (for example, from changing the rules for the formation of pension rights).

## **4. Purpose of the Study**

The purpose of the study is to assess the capabilities of the Russian financial market as a source of alternative pension capital and to propose the creation of alternative ‘quasi-retirement’ products.

## **5. Research Methods**

The study is based on the systematization of actual material on the formation of alternative pension capital through the tools of the Russian financial market using the methods of systematic and comparative analysis, induction and deduction and is supported by tabular and graphical methods of data illustration.

## 6. Findings

### 6.1. Alternative pension capital: concept, formation mechanism

The term “alternative pension capital” is practically not used in Russian practice. This is caused by the fact that the concept of pension capital is mainly considered as a certain amount of contributions in the form of cash, accumulated in the pension fund, involved by its owner into the economic process in order to obtain the retirement income (Mazhara, 2006). At the same time, the right to receive it (in full or annuity payments) arises only after reaching a certain age (or other conditions) established in the national legislation. This approach does not take into account other financial instruments that allow the formation of pension capital, but which cannot be attributed to classic pension instruments.

Within this study, alternative pension capital refers to trust funds of individual/family/household funds and material assets formed through financial and non-financial instruments not directly intended for this (Grigorieva et al., 2017).

The fundamental principles required to identify the alternative pension capital are as follows:

- 1) targeting in the formation of capital is a specific goal, passive income upon termination of work for objective or subjective reasons;
- 2) tools and methods are not directly designed to form pension capital in the classical understanding of financial science;
- 3) lack of regulation of these relations by pension legislation;
- 4) financial and non-financial assets (Grigorieva et al., 2017).

Considering the mechanism for the formation of alternative pension capital it should be said that it differs depending on the form of assets. As noted earlier, assets may be financial and non-financial (but capable of generating income or converting it into money). Figure 1 shows the economic mechanism (Frolov & Shulimova, 2013; Inshakov, 2009) of the alternative pension capital.

The subject of control is an individual ( $S_0$ ). The subject of management in accordance with personal (family) financial opportunities and priorities, under the influence of the external environment ( $E_0$ ) (pension risk landscape) determines the key vectors of the pension strategy ( $P_0$ ). The result ( $R$ ) expressed in the cash trust fund is achieved through the use of a combination of external and internal impacts – resourcing ( $F$ ); methods ( $M$ ); tools ( $J$ ); information support ( $Inf$ ).

The change of the size of the pension capital ( $R$ ) requires assessing the level of its achievement in accordance with the given pension strategy of an individual (Yushkova & Doroshenko, 2019). For this, a system of criteria for evaluating the results obtained ( $K_0$ ) is used. The elements of such a system include the creation of a database ( $B$ ); analysis ( $A$ ); diagnostics ( $D$ ); assessing the state and prospects ( $H$ ) of a given pension strategy.

The assessment allows identifying a deviation from target values and applying corrective measures ( $K_1$ ) to the pension strategy in order to obtain a given amount of alternative pension capital.

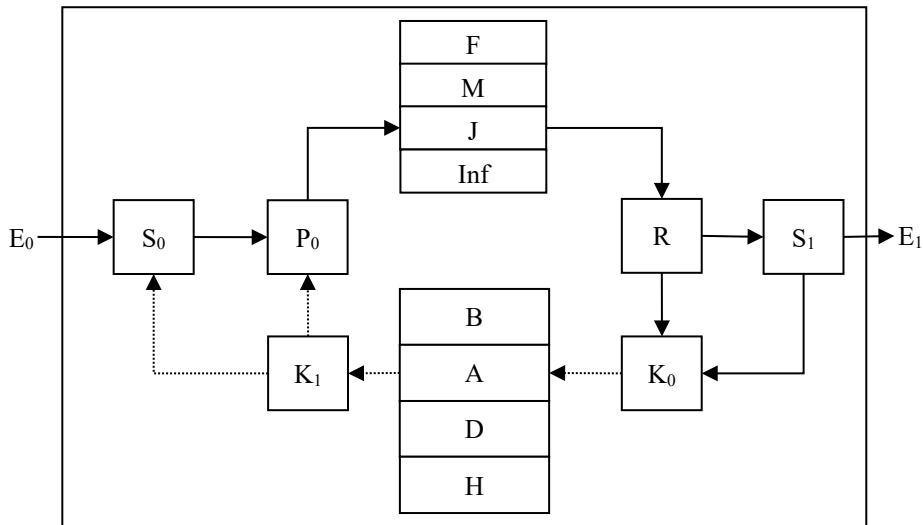

**Figure 1.** Economic mechanism for alternative pension capital

## 6.2. Tools for alternative pension capital in the Russian financial market

As mentioned earlier, alternative pension capital instruments may be financial and non-financial. Financial instruments for the formation of alternative pension capital include all possible non-specialized financial instruments available for use by the population, which will allow them forming a source of passive income in the future. In particular, securities (bonds, shares, savings certificates, investment shares and others), deposits (in national and foreign currency) in commercial banks, metal accounts, individual investment accounts, and others. Non-financial instruments include real estate, antiques, “reverse mortgages” (life care contracts for a pensioner in exchange for his real estate) and others (Grigorieva et al., 2019).

Focusing on financial instruments, an individual may use them directly or through financial intermediaries, since the legislation of the Russian Federation limits the number of persons for whom the access to the financial market is open (in its broad sense). Therefore, Table 1 presents the main financial instruments available to the population in order to form alternative pension capital in the Russian financial market.

**Table 1.** Financial instruments of the Russian financial market for the formation of alternative pension capital

Financial instrument	Comment	Population access to tools
Deposit	Ruble or currency deposit in a bank	Direct/Through financial intermediaries
	Metal accounts	Direct/Through financial intermediaries
Securities	Russian and foreign shares, depository receipts, investment shares of mutual funds, MIS, ETF, bonds denominated in rubles and foreign currency, mortgage securities, Eurobonds	Through financial intermediaries
Foreign currency	Spot deals, forwards, currency swaps, derivatives	Through financial intermediaries

Most financial instruments involve indirect public access to the financial market. This requires different methods that not only provide access to single financial instruments, but also allow forming an aggregate investment portfolio that includes different types of financial instruments (trust management, individual investment accounts (IIA), etc.).

### Analysis of the possibilities of financial instruments in the formation of alternative pension capital

The potential of each individual financial instrument in the formation of alternative pension capital cannot be considered exclusively in its pure form. As practice shows, the population chooses a portfolio approach and the previously presented financial instruments are not used by the population in their net form (with the exception of deposits). This makes it possible not only to diversify the investments, but also to facilitate the selection of an optimal set of financial instruments depending on subjective attitudes and personal financial capabilities of individuals.

Therefore, the study considers the IIA as the most affordable portfolio for a wide range of the Russian population (Grishchenko & Maratkanova, 2017). Besides, let us consider the potential of deposits as the most conservative financial instrument.

According to the Bank of Russia (Figure 02), the number of IIA contracts in credit and non-credit organizations is rapidly growing (Indicators of financial accessibility, 2018, 2019).

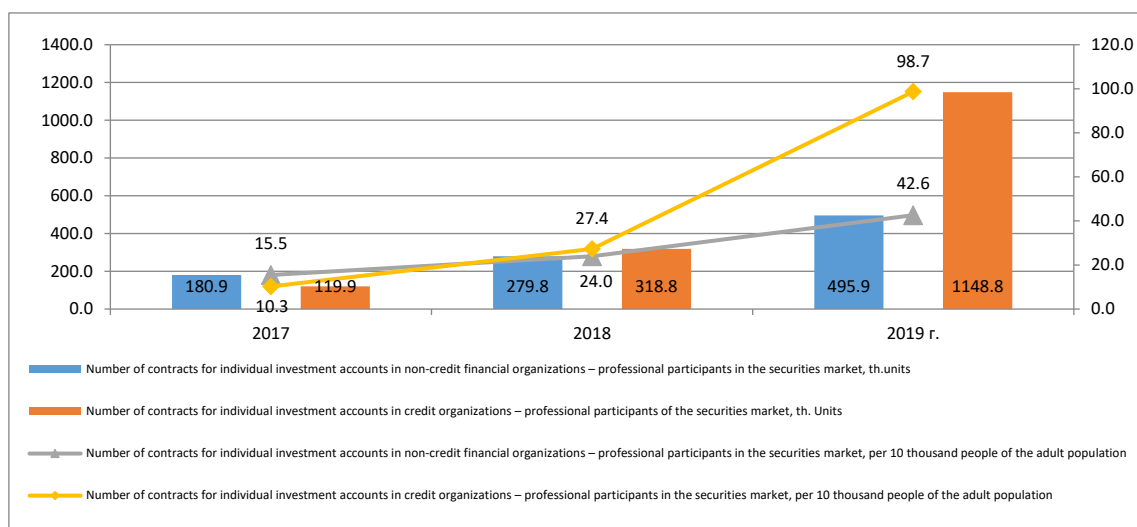
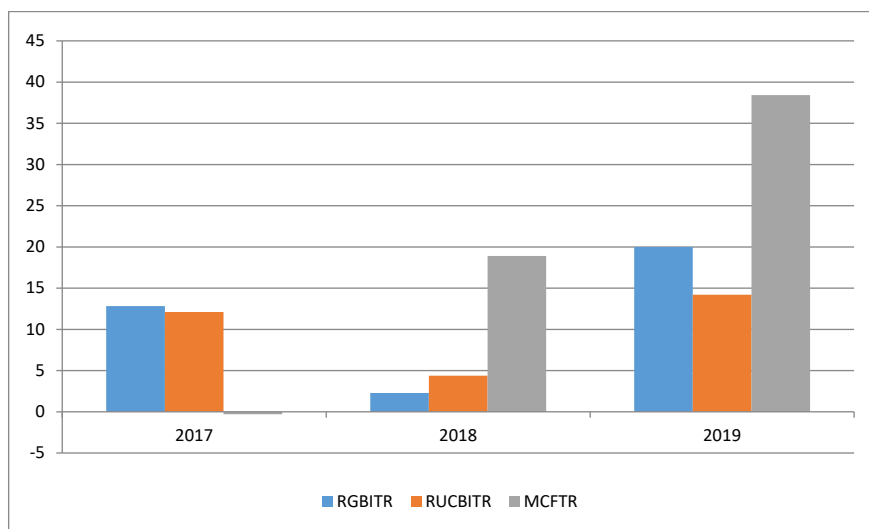

**Figure 2.** Number of contracts for individual investment accounts in credit and non-credit organizations of Russia for 2017–2019 (Indicators of financial availability, 2019, 2018)

Since 2017, the number of IIA contracts in non-credit organizations has increased by 173 %, and in credit organizations – by 858 %. It is noteworthy that according to 2017 data, individuals preferred the opening of IIA in non-credit organizations, but since 2018, the IIA segment in credit organizations began to grow rapidly.

This development is caused by the fact that large federal Russian banks (Sberbank, VTB, etc.), having a wide client base for the main type of activity, actively promote IIA within their digital

ecosystems. At the same time, they not only offer the product itself, but also carry out explanatory work with their customers. Besides, higher realized incomes (Figure 03) in previous periods and the possibility of receiving a tax deduction for personal income tax push the individuals to open the IIA.



**Figure 3.** Dynamics of financial instrument indices, % (Overview of the Russian financial sector and financial instruments, 2019)

If we consider the values of net assets on IIA (Table 2), we see that in non-credit financial organizations the indicators are higher than in credit organizations. At the same time, the number of IIA contracts in non-credit organizations is much less.

**Table 2.** Indicators of net assets and the average size of IIA in credit and non-credit organizations (Overview of key indicators of professional participants in the securities market, 2019)

Indicator	Unit of measure	2018	2019
Value of assets on IIA, including:	bln rub	98.4	197.3
- professional participants – non-credit organizations	bln rub	68.1	125.0
- professional participants – credit organizations	bln rub	30.7	72.3
Average IIA size in brokerage services	th.rub	127.1	92.2
Average IIA size in trust management	th.rub	408.9	301.1

In addition, the average amount of IIA in trust management is higher than in brokerage services. The gap is tens of thousands of rubles. This is caused by the presence of a minimum threshold for investing in trust management (50 thousand rubles according to the most popular strategies), while there is usually no minimum threshold for brokerage services.

According to the Bank of Russia, a significant part of the total number of IIA remain “zero” (without assets in the account) or trial (with a small amount of assets in the account), since often the IIA is opened automatically when concluding a contract of the main brokerage account and then is not used.

If we consider the indicators on deposits of the population (Table 03), then there is a slight positive dynamics, the pace of which slows down during the study period. This is caused by the decrease in the weighted average rates on fixed-term deposits, with a simultaneous increase in inflation, which reduced

the already small yield on deposits. All this pushes the population to look for and choose riskier and more profitable financial instruments.

**Table 3.** Indicators of funds of individuals in deposits at the end of the year (Statistical indicators of the banking sector of the Russian Federation, 2019)

Indicator	2017	2018	2019	Growth rate, %	
				2018 to 2017	2019 to 2018
Funds (deposits) of individuals (billion rubles)	25 987.4	28 461.1	30 549.0	109.5	107.3
in % of GDP	28.3	27.2	27.8	96.1	102.1
in % of the monetary income of the population	46.2	48.7	49.2	105.3	101.1
Weighted average deposit rates, %	7.38	6.29	6.24	-	-
Inflation rate, %	2.52	4.27	3.05	-	-

Given the long-term horizon of implementing a personal pension strategy, the use of deposits, with a similar dynamics, will not be able to provide an acceptable level of income to an individual after retirement. But deposits are distinguished by high financial accessibility (in terms of income, in the presence of a developed financial infrastructure), and they impress people with a conservative pension strategy in connection with the country's personal deposit insurance system. Therefore, to meet the needs of the market this financial instrument requires the introduction of innovations.

#### 6.4. Prospects of using financial market opportunities for alternative pension capital in modern Russia

The study of selected financial market instruments for alternative pension capital development shows that there is good potential. However, there are deterrence factors – these are disposable incomes of the population; underdeveloped regional financial infrastructure (Table 04); financial literacy and sometimes irrational financial behavior.

**Table 4.** Financial services infrastructure: regional section (Indicators of financial accessibility, 2019, 2018; Rosstat, 2020)

Subject of the Russian Federation	Disposable incomes of the population, in % to the previous period		Credit institutions			Professional participants in the securities market		
	2018	2019	Number of credit institutions – head offices		Number of separate divisions of credit institutions	Number of professional participants in the securities market (not credit organizations)		
			2018	2019		2018	2019	2018
Russian Federation	100.1	101	484	442	1001	897	297	263
Central Federal District	99.8	102	272	253	197	172	218	197
Northwest Federal District	101.4	99.8	41	37	134	118	26	23
Southern Federal District	100.8	99.5	25	24	103	91	9	5
North Caucasus Federal District	98.4	100.5	12	10	48	41	1	1
Volga Federal District	98.8	100.7	67	57	173	154	23	16

Ural Federal District	100.6	101.2	23	23	137	127	11	12
Siberian Federal District	99.8	102	28	23	133	125	8	7
Far Eastern Federal District	99.7	100.2	16	15	76	69	1	2

The elimination of deterrence factors is only possible through the systematic work of state authorities, financial organizations and the population.

For this purpose, the option of introducing a new type of IIA is being considered as part of the development of individual investments of the population. The difference from the existing forms is its long-term (from 10 years) and the absence of a limit on the amount of annually contributed funds.

As stated in the Concept of improving the mechanism of an individual investment account to stimulate long-term investments in the Russian Federation, this type of IIA will be targeted, namely, the purchase of pension plans; lifetime annuities; obtaining rent.

Another area is the introduction of the practice of irrevocable (pension) deposits in Russia (Lisitsa, 2012), in the framework of which banks will be obliged to provide a fixed deposit rate. The introduction of pension bank deposits will be quite attractive for the population due to the high level of confidence in banks.

## 7. Conclusion

In conclusion it should be noted that the concept of alternative pension capital for Russians is becoming ever more relevant. The current state system of pension protection is not able to provide a high standard of living for pensioners, therefore, it is necessary to find other ways and methods. The analysis of the economic mechanism for forming an individual's alternative pension capital made it possible to determine the range of financial instruments of the Russian financial market available to the population. The most promising of them are IIA, which has been proven empirically.

The only disadvantage of this tool is its short-term (3 years), as a result of which we agree with the proposal of the Bank of Russia on the need to introduce a new IIA concept. The advantages of a new type of IIA are the long-term and lack of limits on the contributing some tax benefits. Another area is the introduction of an adapted system of irrevocable bank (pension) deposits.

It should be noted that this is not the only option of using financial market opportunities to form the alternative pension capital. The presented results are not a comprehensive disclosure of all the capabilities of the Russian financial market as a source of alternative pension capital.

## References

- Frolov, D. P., & Shulimova, A. A. (2013). Institutional system of social responsibility of business (nature, institutions, mechanism). *JIS*, 1, 124–144.
- Grigorieva, L. V., Gorshkova, N. V., & Mytareva, L. A. (2017). Economic mechanisms of population protection against pension risks as a tool for socio-economic development of the region. *J. of Volgograd State Univer. Ser. 3 Econ. Ecol.*, 1(38), 31–44.



- Grigorieva, L. V., Mytareva, L. A., & Shkarupa, E. A. (2019). Failure of the Funded Model of the Russian Pension System. *Reasons and Solutions Lecture Notes in Networks and Systems*, 57, 371–384.
- Grishchenko, N. B., & Maratkanova, I. V. (2017). Modern opportunities for individual pension savings of the population in the regions on the example of the Siberian Federal District. *Regional economics: theory and practice*, 12, 2291–2307.
- Inshakov, O. V. (2009). *Mechanisms for implementing the strategy for the formation of the nanoindustry in the regions of Russia*. Publishing House of Volga State University.
- Lisitsa, M. I. (2012). Concept and tools of investment approach to pension provision. *Finance and Credit*, 17(497), 20–29.
- Mazhara, E. N. (2006). A systematic approach to the investment process in the pension capital market. *Economics and management: scientific and practical journal*, 1(87), 64–69.
- Yushkova, S. A., & Doroshenko, M. V. (2019). Strategies for pension behavior in the conditions of reforming the pension system. *Power*, 1, 41–46.