

RPTSS 2018
International Conference on Research Paradigms
Transformation in Social Sciences

ADDITIONAL POWER LOSSES IN LOW-VOLTAGE
ELECTRICAL NETWORKS AND THEIR INFLUENCE ON
PEOPLE

I.V. Naumov (a)*

*Corresponding author

(a) Irkutsk National Research Technical University, Lermontov Str., 83, Russian, professornaumov@list.ru,
89246988990; (b) Amur State University 21 Ignatievskoye Shosse, Blagoveshchensk,
Russia professornaumov@list.ru

Abstract

The paper is concerned with the problem of additional currents under unbalanced loads. Additional negative- and zero-sequence current components (except for the positive sequence current) flow through phase wires of a three-phase system while the neutral wire carries three zero-sequence currents. This causes both the unaccounted power losses that exceed the cost of similar losses under balanced loads many times, and, which is very important, additional heating of conductor material. This in turn greatly increases heat losses from the conductor surface, which leads to single-phase and multiphase short circuits in the cable electrical networks with neutral conductor. Moreover, these short circuits cause not only electrical equipment failure but also, which is of great concern, fires accompanied by deaths and traumatism of people and considerable material damage. The paper is focused on the fact that the unbalanced load in electrical networks with that of neutral is an objective phenomenon. Therefore, the only effective way to minimize additional power losses and reduce fire hazard is to use special shunt balancers with automated control of their parameters.

© 2018 Published by Future Academy www.FutureAcademy.org.UK

Keywords: Unbalanced of currents, additional loads, fire risk, power loss increase factor.



1. Introduction

Currently, the design of interior wiring in residential and production premises is based on four-core and five-core cables with three phase conductors and one neutral or three phase conductors and one neutral and one grounding conductor. Until now, this has been done based on the assumption that the single-phase loads are balanced in three-phase systems, and geometrically, the sum of currents in the neutral conductor equals zero. However, this does not categorically correspond to reality, since in real operation conditions of household electric devices there is always considerable unbalance of phase currents. There are three main kinds of such unbalance: *nonrandom* (systematic) current unbalance caused by non-uniform distribution of single-phase loads in the indoor or intrashop three-phase electrical network; *random current unbalance* caused by the probabilistic nature of switchings of single-phase loads; and *element current unbalance* caused by failure of one or two elements of the three-phase balanced load (for example of a three-phase element water heater). Since in any of these three cases, the balance is violated according to the method developed by Charles Fortescue in 1918, apart from the main positive-sequence current, each of the conductors starts to carry also additional zero- and negative- sequence currents, and neutral conductor carries three zero-sequence currents.

2. Problem Statement

2.1. Additional heat losses and their impact on the cable core insulation

Additional power losses in the network caused by unbalanced current are characterized by power loss increase factor K_p :

$$K_p = \Delta P_N / \Delta P_S = 1 + K_{2I}^2 + K_{0I}^2 (r_0 / r_1), \quad (1.1)$$

where ΔP_N - power losses in the network under unbalanced conditions; ΔP_S - power losses in the network, caused by positive-sequence currents; K_{2I} - negative-sequence current unbalance factor; K_{0I} - zero-sequence current unbalance factor; r_0 , r_1 - zero-sequence resistance and positive-sequence resistance, respectively.

For a three-phase four-wire line, as it is noted in F.D. Kosoukhov's work we will have (Kosoukhov, 1988):

$$K_p = 1 + K_{2I}^2 + K_{0I}^2 (1 + 3r_N / r_F), \quad (1.2)$$

where r_N , r_F - active resistance of neutral and phase conductors of the line.

With the same cross-section of phase and neutral conductors of a 0.38 kV overhead line, the ratio for the line is $R_0 / R_1 = 4$. Then expression (1) is transformed as follows:

$$K_p = 1 + K_{2I}^2 + 4K_{0I}^2. \quad (1.3)$$

Consequently, value K_p is more affected by factor K_{0I} , whereas factor K_{2I} has much lesser influence on it.. Thus, if under the conditions of uniform electricity consumption (under the same load of

phases) the neutral conductor temperature is not high, then under unbalanced currents in the neutral conductor there will be a current of considerable magnitude equal to three zero-sequence currents, which will greatly increase the power loss factor.

2.2. Impact of an insulated conductor heating temperature on the insulation quality

The installation of indoor wiring tends to upset the uniform distribution of single-phase loads, and probabilistic unbalance of currents leads to even greater additional heat losses. Normally, the indoor electric wiring is installed with the cables that have polyethylene insulation and aluminum cores with a cross-section from 1.5 mm² (lighting networks) to 2.5 mm² (socket network). According to (Wires and cables for electrical units on nominal stress up to 450/750 B inclusive, 2010; Rule of Devices of Electroinstallations (RDE), 2000), the admissible current for buried wiring does not exceed 14-20 A. However, the admissible current is the maximum current that can be carried by the conductor with a set cross-section, provided that the admissible temperature is not exceeded, i.e. for the balanced conditions. Cross section of the conductor should not exceed the established temperature. This means that the cross-section is selected when performing a condition $K_p = 1$. However, the cross-section is always selected disregarding the zero-sequence flows in the neutral conductor in the 0.38 kV network. Thus, first of all, the cross-section of the chosen conductor is artificially underestimated, and secondly the rated parameters of the automatic the device protecting the line will also be chosen improperly since it is also selected based on the working current. Since the cross-section of the neutral conductor is not larger (and sometimes even smaller) than the cross-section of the phase conductor, the flowing three zero-sequence currents overheat the insulation which results in its melting and causes a single-phase short circuit. In the event that the automatic circuit breaker in the main section of the network is selected inappropriately (i.e. it is not checked for operation sensitivity under minimum short circuit conditions), the protection device fails to operate in case of a short circuit in some remote part of the network. As a result, fires take place in individual houses in rural populated settlements, cottage areas, urban flats, and in production rooms. The carried-out analysis of literature on the fire, shows that their main reasons are overloads and short circuits (Ward, 2015; Jesse, 2015; Zalok, Hadjisophocleous & Loughheed, 2009; Marxsen, 2017; Clapa, 2015; Walters & Hastings, 1998; Tsui & Chow, 2004; Hadjisophocleous & Chen 2010; Baratov, 1997; Harmon, 2017). However, none of the sources has ever considered the overload of a neutral conductor due to unbalanced phase currents as a cause for these conditions. Moreover, it is worth noting that the developed measures, methods and technical for decrease in asymmetry of currentse have never been considered as a tool for prevention of fires. Therefore, we are the first to suggest the use of balancers as a way to stabilize fire-hazardous conditions.

3. Research Questions

To achieve the goal of the research, it is necessary to solve the following *tasks*: 1) to substantiate the emergence of additional heat losses, 2) to carry out experimental research on their detection; 3) to analyze the dynamics of fires and their consequences; 4) to develop a special technical tool to minimize the symmetry components of zero-sequence currents.

4. Purpose of the Study

The purpose of the present research is to develop special technical devices (balancers) which when installed in the operating outdoor and indoor electrical networks will make it possible to reduce zero-sequence currents and minimize the possibility of fires.

5. Research Methods

The main method for the research is the method of symmetrical components which was applied to devise an algorithm and a program for calculation of additional power losses. Their use enabled experimental research in operating 0.38 kV electrical networks.

6. Findings

6.1. Experimental research of unbalanced conditions in operating 0.38 kV electrical networks

Over many years, we have been involved in the research into unbalanced conditions of distribution 0.38 kV networks in Leningrad and Irkutsk regions, Germany and Mongolia. More than 30 years, we have studied the unbalanced conditions in the outgoing transmission lines of a great number of rural transformer substations, what was noted in our publications for this period (Kosoukhov, 1988; Kosoukhov, 1985; Naumov, 2001; Naumov, Horenkamp & Schulz 2005; Damdinsuren, 2016). To exemplify, we can present some data on the results of measurements and calculations, for the Irkutsk region on one of the transformer substations with 4 outgoing transmission lines supplying residential-commercial load. The research was being done all the year round: in winter, spring, summer and autumn.

Table 01. Results of experimental research on Transformer substation 5

Season	Line	U_A	U_B	U_C	U_{AB}	U_{BC}	U_{CA}	I_A	I_B	I_C	I_N	I_{BC}	$K_{\Sigma i}$	K_{0i}	K_p
Winter	L1-1	238	244	232	390	390	390	12.76	9.30	35.41	24.24	30.46	0.475	0.453	2.426
	L2-1	237	243	235	390	389	390	27.49	35.18	23.21	19.14	32.75	0.386	0.234	1.423
	L3-1	239	242	233	390	390	390	36.19	34.37	60.43	26.28	49.82	0.475	0.245	1.542
	L4-1	239	244	233	390	390	389	11.59	22.63	21.28	15.93	22.75	0.638	0.297	1.878
Spring	L1-2	228	230	225	402	402	400	14.23	7.45	27.88	20.82	27.99	0.467	0.495	2.42
	L2-2	228	230	225	402	402	400	19.45	29.12	20.71	14.74	26.83	0.498	0.208	1.618
	L3-2	234	237	230	401	401	400	47.65	29.81	38.07	21.27	43.03	0.301	0.294	1.314
	L4-2	233	236	230	401	401	400	17.96	17.65	9.53	13.25	15.41	0.344	0.437	1.529
Summ	L1-3	225	217	228	380	389	392	8.17	10.91	10.23	6.29	11.12	0.416	0.23	1.427

	L2-3	234	237	230	401	401	400	47.65	29.81	38.07	21.27	43.03	0.404	0.53	1.44
	L3-3	225	217	227	380	388	391	14.58	18.44	9.28	17.96	16.58	0.718	0.13	3.255
	L4-3	225	217	228	380	389	392	34.19	33.83	30.74	10.65	35.83	0.266	0.24	1.124
Autumn	L1-4	231	224	230	396	398	398	10.88	15.90	18.40	10.63	15.61	0.598	0.344	1.946
	L2-4	230	222	230	394	397	398	26.74	33.60	24.73	16.12	35.00	0.32	0.232	1.355
	L3-4	231	224	229	396	397	398	41.14	45.25	28.37	24.11	48.76	0.305	0.218	1.355
	L4-4	231	223	229	395	396	396	19.03	18.70	16.53	10.65	21.82	0.34	0.292	1.377

Based on an analysis of the data only for one (the first) outgoing transmission line, we can state the following. In winter, the value of the neutral conductor current in this line is 21.3 percent higher than the mean value of the currents in three phases. In spring, it is 26 percent higher; in summer, it is 35 percent lower, and in autumn – 30 percent lower. On the whole for the year, however, the value of neutral current is 8.1 percent lower than the mean value of current in the three-phase system, i.e. only by 1.3A. At the same time, an average value of the power loss factor for the same transmission line was 2.06, i.e. power losses under unbalanced operation of the transmission line exceeded the corresponding losses under balanced operation more than two times. Consequently, the value of the neutral conductor current in the conditions of sufficient current unbalance is comparable with the average value of current in the three-phase system.

Thus, a considerable increase in the neutral current of indoor cable wirings with the neutral conductor can be one of the main reasons for the fires in residential and industrial premises, posing a threat to the lives of people and animals.

6.2. An analysis of fires dynamics in the Irkutsk region

Let's pass to the analysis of the causes of the fires in the Irkutsk region. The analysis is carried out during 2000-2014 in the cities and rural settlements. On the published data of Head department of the Ministry of Emergency situations on the Irkutsk region (MDC Prevention of fire spreading, 1997). and also according to the data of Chief Administration of the Ministry of Emergency Situations of the Russian Federation in the Irkutsk region (Information letter of Chief Directorate of the MES for the Irkutsk region, 2014), “the total of the fires made 70246”, as shown in Figure1 (Naumov, Ivanov, Podiyachikh, & Shpak, 2007). It should be noted that more than 20% from all number of the arisen fires fell to the share of those that were the result of violations of the Rules of devices and operation of electric equipment (further in the text “Rules”). From the considered number of fires as it is noted in (Naumov, Ivanov, Podiyachikh, & Shpak, 2007), largest number of fires was observed in 2002, what made 9%, and the smallest number of fires - in 2014, approximately near 4%.

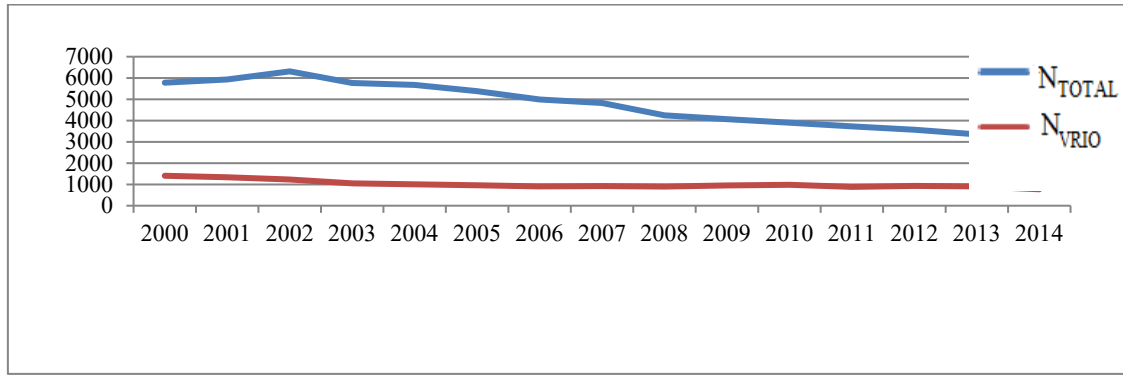

Figure 01. The temporary chart of change of the number of fires across the Irkutsk region

Change of the number of fires for a cause of infringement of Rules is presented in figures 2 and 3.

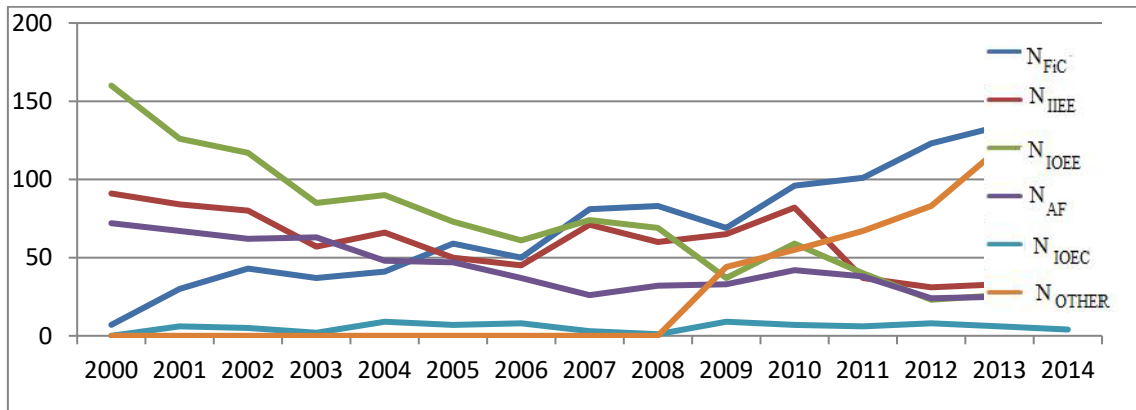

Figure 02. Temporary chart of change of the number of fires in city premises

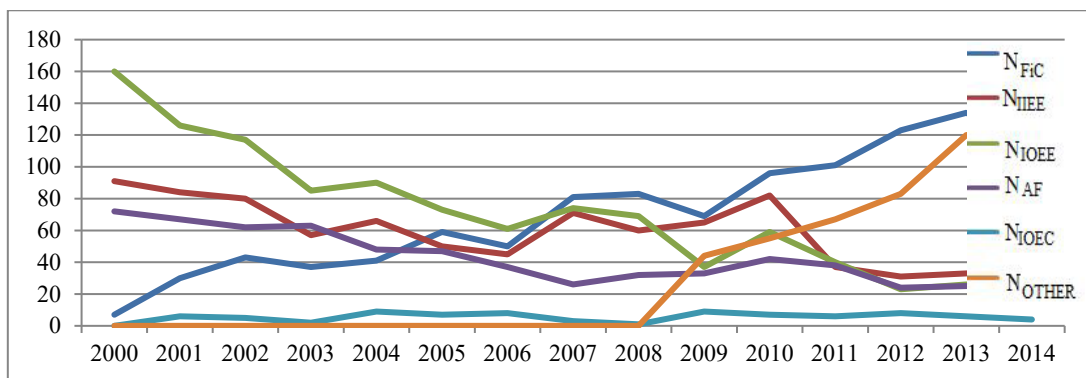

Figure 03. Temporary chart of change of the number of fires in rural premises

In the submitted figures (1 and 2) it is designated: 1) N_{FIC} - the number of fires for the reason of fault in construction and manufacture of electrical equipment; 2) N_{IIEE} - the number of fires for the reason of improper installation of electrical equipment; 3) N_{IOEE} - the number of fires for the reason of improper operation of electrical equipment; 4) N_{AF} - the number of fires, the electric devices caused by misuse; 5) N_{IOEC} - the number of fires, the protection devices caused by the wrong choice in internal electroconductings; 6) N_{OTHER} - the number of fires, the "Rules" caused by other causes of infringement.

The analysis of the submitted charts on figure 2 and 3 showed that the total of the fires for 2,3 and 4 reasons in 2014 are decreased. For example the number of fires for 2 and 4 reasons decreased more, than by 90% in urban areas and more than 60% in rural areas. The number of fires, the protection devices caused by the wrong choice in internal electroconductings practically remains invariable. And, at last, the number of fires for the 6th reason has a resistant tendency to increase. Apparently (figures 2 and 3) for urban areas such increase made more than 50% of charts, for rural areas - more than 60%. In figures 4 and 5 the temporary charts characterizing consequences of the fires in urban and rural areas are submitte. In the submitted figures it is specified: Ndead p. – the number of the died people; Ninj.p. - number of the people who were traumatized; Ndead cat. – number of the dead of animals; Ndead small cat - quantity of the died small animals.

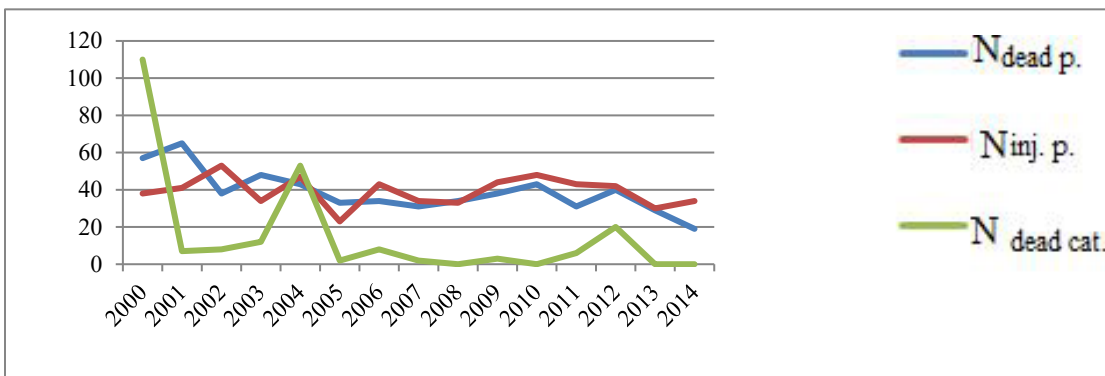

Figure 04. Temporary charts of consequences of the fires in urban area

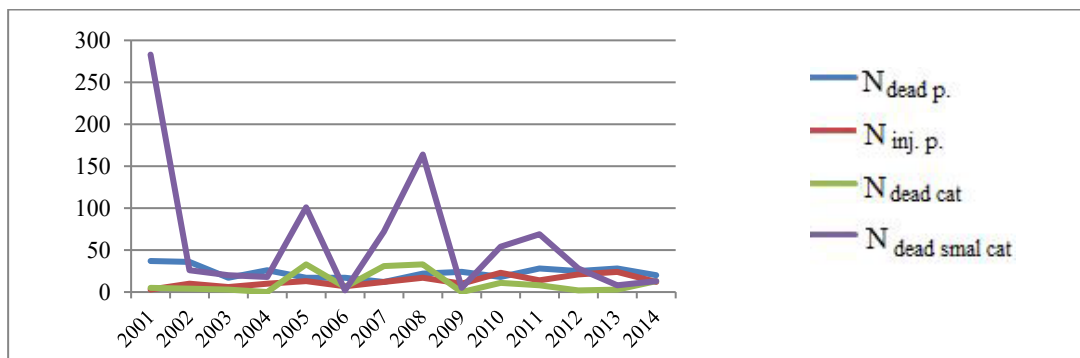

Figure 05. Temporary charts of consequences of the fires in rural area

Apparently from the submitted charts, in the cities died and it is injured, respectively 583 and 774 persons, in rural areas 343 persons died, 187 people were traumatized. Besides, the number of the dead of animals in the cities and rural areas, was 231 and 262 respectively. As is seen from the analysis, the fires that occurred during the studied period led to drastic consequences: deaths of people and animals, and considerable material damage. Besides, the arising fires result in significant material damage. Apparently for a cause of infringement of "Rules" in city and rural settlements the material damage was the fires of figure 6, respectively 570630 and 202147 thousand rubles.

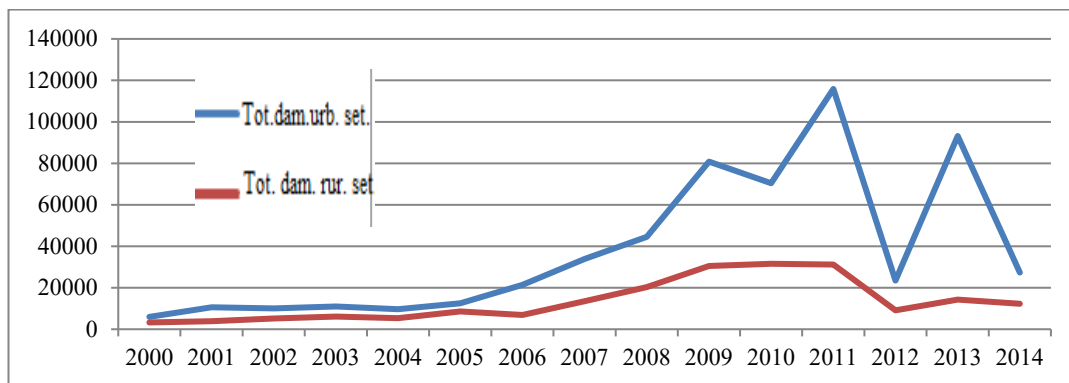

Figure 06. Temporary charts of change of direct material damage as a result of the fires in city iselsky settlements (in thousand rubles)

6.3. Development of the express balancing device

Our analysis of literature sources confirmed that one of the dangerous manifestations of electric current, from the standpoint of fire danger, is certainly its thermal effect. Conductors that draw the current exceeding the rated value begin to overheat. This can lead to an increase in temperature leading to ignition of the insulation, which can cause a fire. The temperature of the conductive core depends on the strength of the flowing current, the ambient temperature, the core diameter and conductor insulation, heat exchange with the environment, the resistivity of the conductor material, and the time of emergency operation. Moreover, none of the sources considers the overloading of the neutral conductor due to unbalanced phase currents as a cause of overload and short-circuit conditions. Along with this, any overloading leading to additional overheating of insulation in intra-apartment or in-house electrical networks and corresponding short-circuits are undoubtedly connected with the current increase in the neutral conductor. Therefore, the development of methods and technologies for balancing the operating conditions of electrical networks that feed the household load and their application in such networks will be the most effective way of preventing fires.

The main principle of this type of shunt-balancing device is the automatic control of its parameters in the function of the zero-sequence current. Each block of this device has the minimum resistance to the zero-sequence currents, which allows the zero-sequence currents to be closed in the section between the unbalanced load and the device connection place.

The use of balancing devices is a real way to reduce fire hazards because of a decrease in the power flows of zero sequence at the phase current unbalance (Naumov, 2001). Their installation at the incoming switchgears of the urban and rural premises will considerably decrease a power loss factor and, hence, prevent the most severe fire consequences. Thus, a decrease in the zero sequence currents flowing through the neutral conductor will make it possible to substantially reduce the power loss factor and decrease the probability of fire to a great extent. To achieve this, we propose using a balancing device with controlled parameters. The device can both decrease phase current unbalance and control zero sequence flows and, hence, minimize energy losses in the device itself in the conditions of minimum current unbalance (Naumov, Ivanov, Podiyachikh, & Shpak, 2007).

A balancing device (Fig.7) for the three-phase four-conductor network with controlled parameters consists of six star-connected capacitors (1-6) and an inductance coil 7 that has an additional terminal 8.

Through one end the inductance coil 7 is connected to a common point of the star and through the other end - to the neutral conductor N9. The points of the star of capacitors (1-6) are connected to the phase conductors of the network (A, B, C). In the first stage of power, three capacitors (1,3,5) and part of inductance coil 7 are connected. As the unbalanced currents and voltage increase, the second stage of power is connected and the power of the device rises. This is achieved through the connection of additional three capacitors (2,4,6) and full coil of inductance 7. The device is completely disconnected from the network (A, B, C) when the current in the neutral conductor N reaches the minimum value corresponding to the admissible value of the current and voltage unbalance. The maximum power of the device is determined by its parameters which can be calculated by the technique described in (Damdinsuren, 2016).

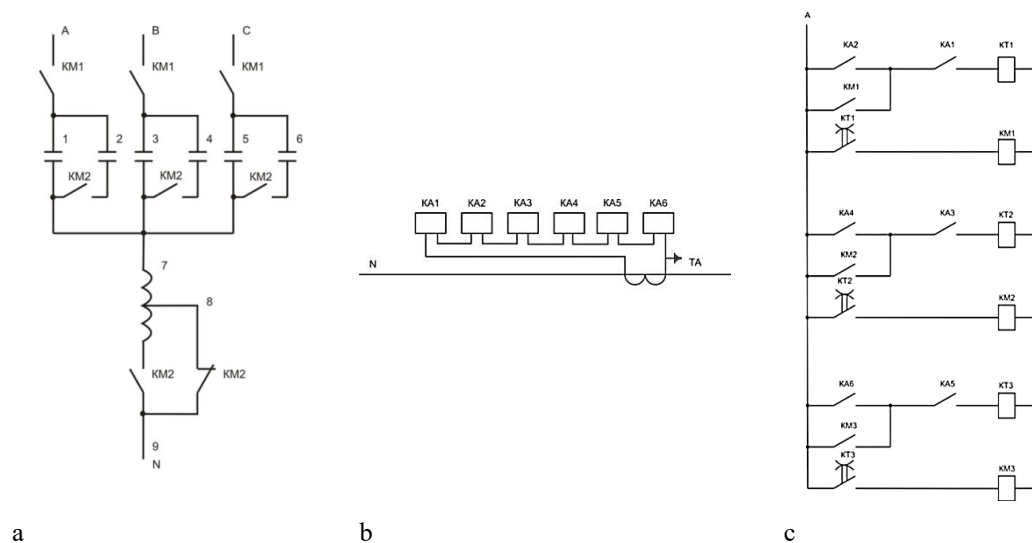

Figure 07. Scheme of the balancing device (a); (b), (c) - schemes of automatic control on the basis of contact-relay elements

7. Conclusion

1. Fires in residential buildings are largely related to the violation of the Rules for design and operation of electrical plants.

2. The main reason why fires occur in these buildings is a considerable increase in the current in the neutral conductor, which is due to the unbalance of the phase currents. This leads to an increase in heat losses caused by the neutral conductor overload, the single-phase short circuits, and, accordingly, to the occurrence of fire.

3. The most effective way to cope with the unbalance of currents in the in-house electrical network is the use of special shunt-balancing devices with automatic control of their parameters.

References

- Baratov, A. (1997). Standardizing industrial fire and explosion Hazards in Russia. *Fire Technology*, 3, 254-259.
- Clapa, I. (2015). Fire incident scenario and test evacuation as key elements in the fire safety management system within buildings. *Safety and fire fighting equipment*, 4, 123-131.
- Damdinsuren, G. (2016). *Upgrading and decrease in losses electric energy in rural networks of 0.38 kV of Mongolia*. The dissertation for a degree of Candidate of Technical Sciences, Moscow, VIESH.

- Hadjisophocleous, G., & Chen, Z. (2010). A survey of fire loads in elementary schools and high schools. *Journal of Fire Protection Engineering*, 1, 55-71.
- Harmon, D. (2017). What Causes Electrical Fires in the Home. Dengarden, *Home Improvement, Electricity & Wiring/Updated on October 5*.
- Information letter of Chief Directorate of the MES for the Irkutsk region (2014). *November 27, 2-8-12-2793*.
- Kosoukhov, F.D. (1988). Power and voltage losses in 0.38 kV rural networks under unbalanced load. *Technique in agriculture*, 5-8.
- Kosoukhov, F.D. (1985). Power and voltage losses in the 0.38 kV rural networks with open-phase branches from the three phase transmission line. *Mechanization and electrification of agriculture*, 30-32.
- Marxsen, T. (2017). *Victoria's journey towards a fire-safe rural electricity distribution network/EECON 2017*, Melbourne, 22-23.
- MDC Prevention of fire spreading. (1997). *Textbook to Construction codes and regulations 21-01-97 "Fire safety of buildings and constructions"*.
- Naumov, I.V. (2001). *Optimization of unbalanced conditions of a rural power supply system. Theoretical conclusions*. Monograph, Irkutsk, Publisher "IrSAA".
- Naumov, I.V., Horenkamp, W., & Schulz, W. (2005). Leistungsverluste durch Spannungsunsymmetrie in Niederspannungsnetzen, Vergleich Russland – Deutschland. *Dortmund Universität, Deutschland*, 4.
- Naumov, I.V., Ivanov, D.A., Podiyachikh, S.V., & Shpak, D. (2007). *The symmetrizing device for three-phase four-wire network with adjustable parameters*. Patent for the useful model No. 61063. It is published 10.02.2007, Bulletin No. 4.
- Roman, J. (2015). *New Fires, New Tactics*.
- Rule of Devices of Electro-installations (RDE). (2000). *7th prod. revised and additional*. M.: Energoatomizdat.
- Tsui, S.C., & Chow, W.K. (2004). *Facilities*, 9-10, 149-164.
- Walters, Megan, & Hastings, E.M., (1998). *Facilities*, 9-10, 246-253.
- Ward, J., H., (2015). *Technology & Engineering*.
- Wires and cables for electrical units on nominal stress to 450/750 B inclusive. (2010). *National Standard of the Russian Federation of GOST P 53768-2010*.
- Zalok, E., Hadjisophocleous, G.V., & Loughed, G.D., (2009). Designing fire experiments for commercial premises. *Journal of Fire Sciences*, 2, 369-403.